

Performance curves

UP 43-110
1 phase 115 V/230 V, 60 Hz

Performance curves

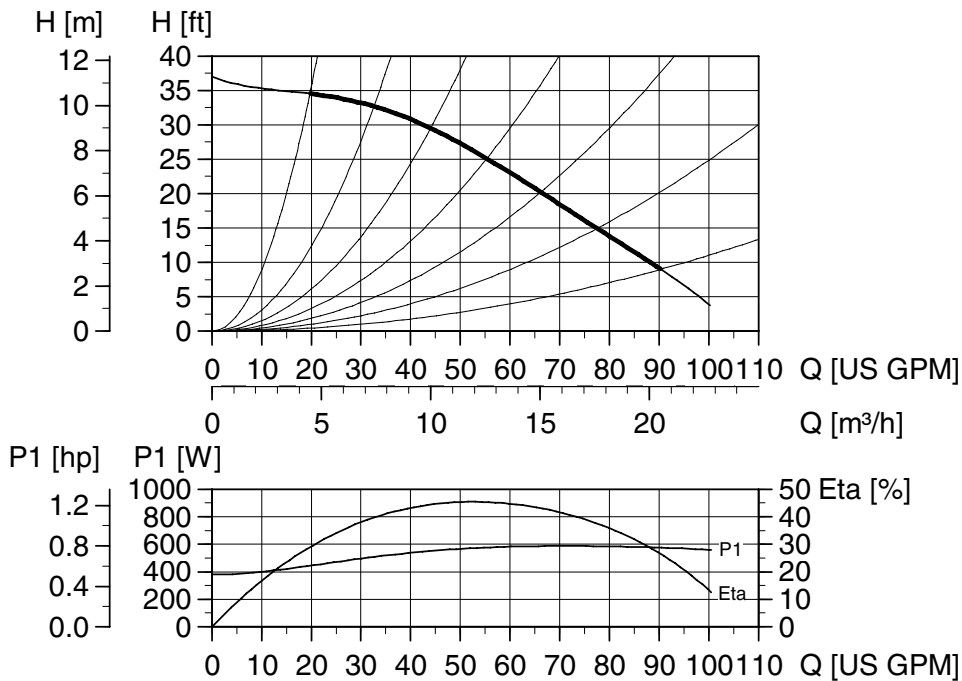

Note: ETA is calculated as wire-to-water efficiency.

Weights and volume

	Cast Iron			
	lbs.	ft ³	Kg	m ³
Net weight	33.1		15.0	
Gross weight	41.2		18.7	
Shipping volume		1.70		0.048

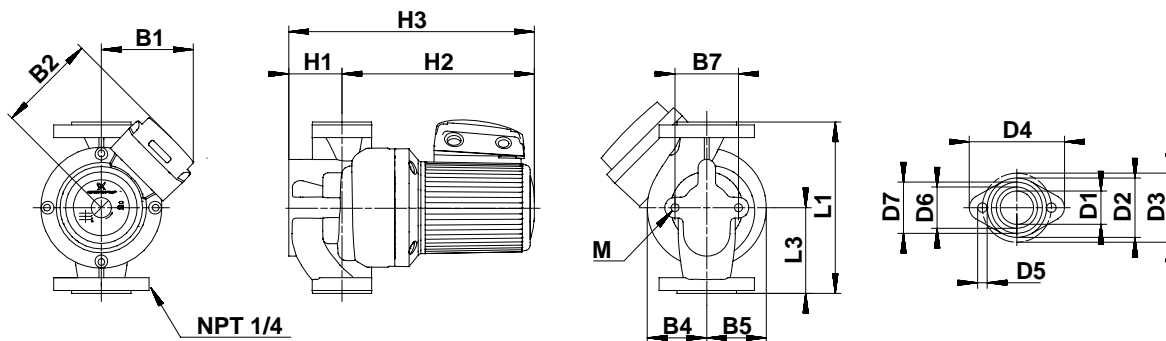

Dimensions

	L1	L3	B1	B2	B4	B5	B7	H1	H2	H3	D1	D2	D3	D4	D5	D6	D7	M
[Inches]	8 1/2	4 1/4	5 1/4	5 9/16	2 15/16	2 15/16	3 1/8	2 5/8	9 5/8	12 3/16	15/8	2 15/16	3 7/16	4 3/4	1/2	2 1/16	2 1/2	
[mm]	216	108	133	141	75	75	80	67	244	310	42	75	87	120	12	52	64.6	12

TM02 0076 4301

TM02 0120 4301