

MAGNA 65-120 F

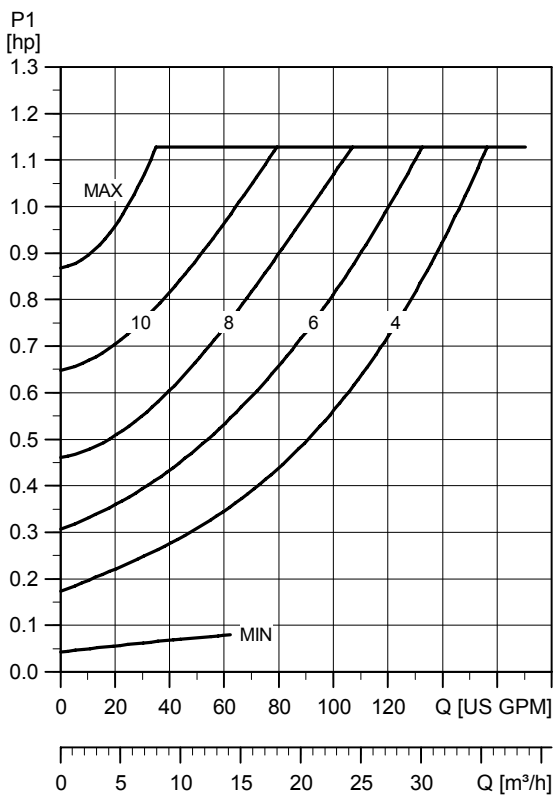
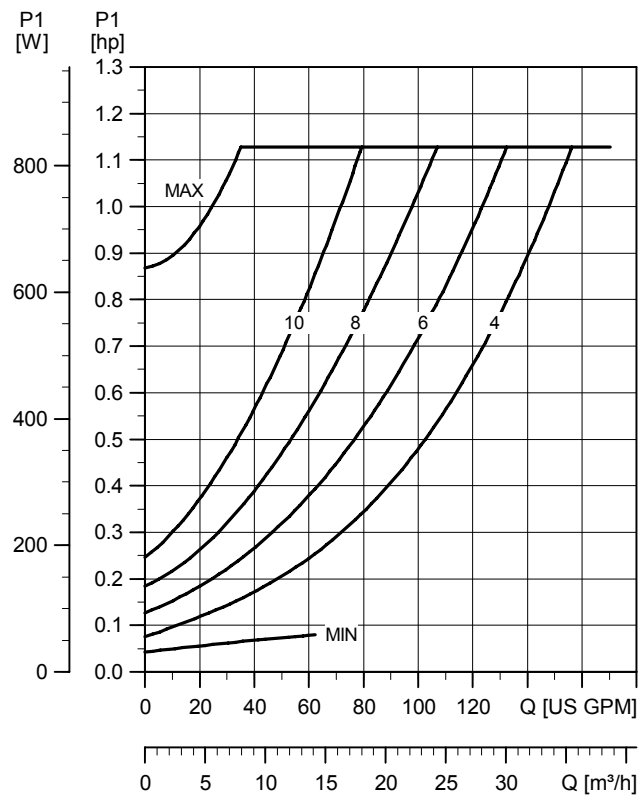
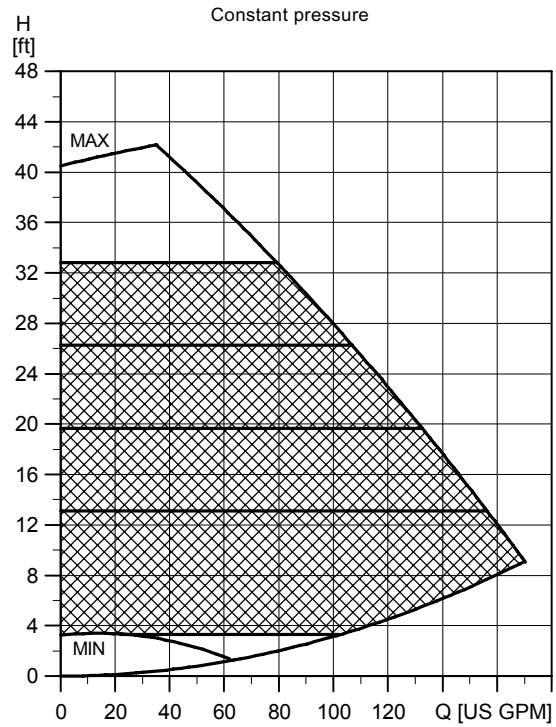
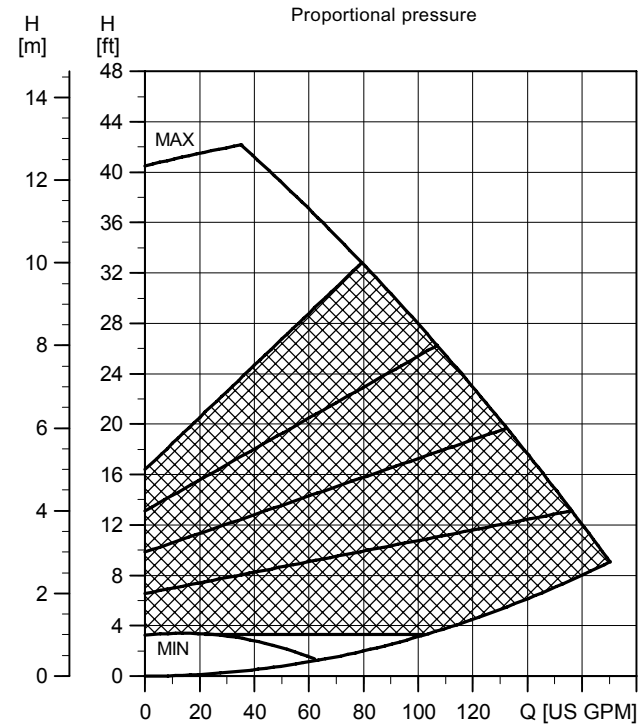

TM03 8794 2507

Performance curves/ technical data

MAGNA 65-120 F

Electrical data

U_n [V]		P_1 [W]	I_{l1} [A]
1 x 230 V	Min.	35	0.28
	Max.	900	3.9

MAGNA 65-120 F is also available with stainless-steel housing, type N.

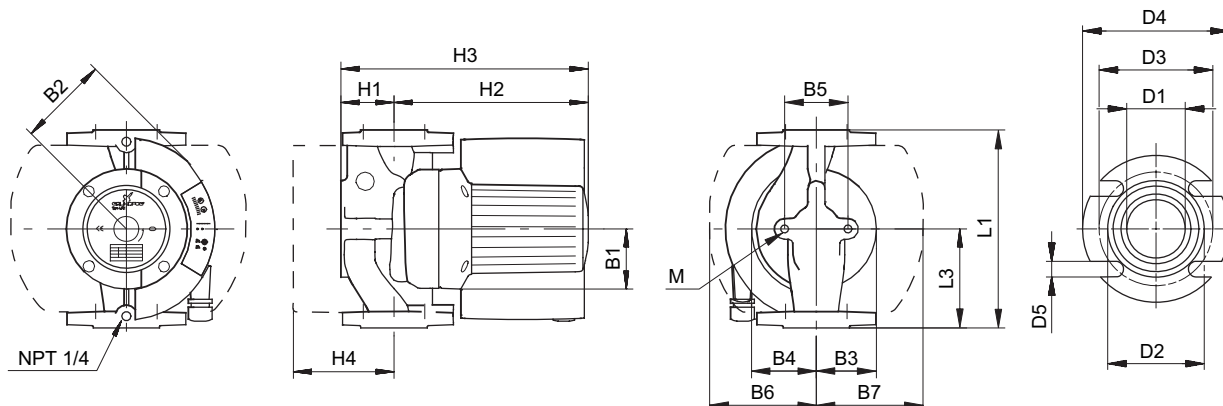

TM03 9058 3307

Dimensions and weights

Pump type	Dimensions [mm]																
	L1	L3	B1	B2	B3	B4	B5	B6	B7	H1	H2	H3	H4	D1	D2	D3	
MAGNA 65-120 F	[in]	11 1/2	5 3/4	3 1/16	4 15/16	3 7/16	4 1/8	3 3/4*	5 1/2	4 5/16	3 1/4	9 15/16	13 1/8	4 3/16	2 1/2	3 15/16	5
	[mm]	292	146	77	125	88	104	96*	140	110	82	252	334	107	63	100	127

Pump type	Dimensions [mm]			
	D4	D5	M	
MAGNA 65-120 F	[in]	6	5/8	M12
	[mm]	152	16	

* Stainless steel pump housing 3 1/8 [in]/80 [mm]

Weights

Pump type	Weights [kg]	
	Net	Gross
MAGNA 65-120 F	56/25.5	60.5/27.5