

**Base Models: 1SV, 2SV, 3SV
and 4SV Major Components**

Series SVA

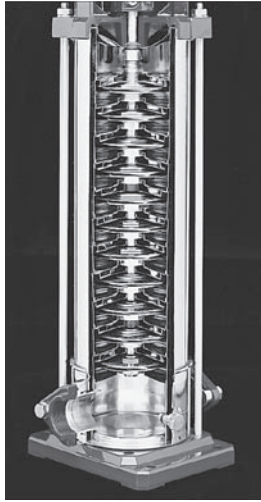

In-line NPT connections

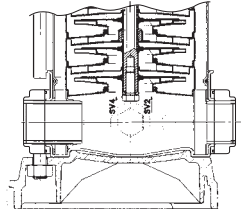

Series SVC



Top and bottom suction/discharge design

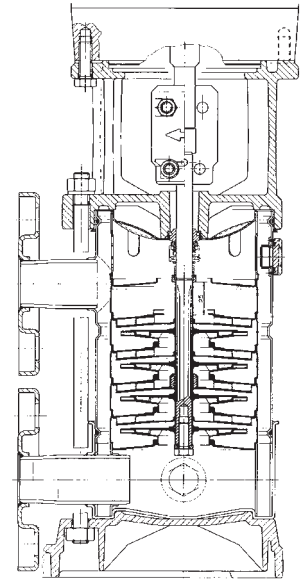

Series SVB or SVD

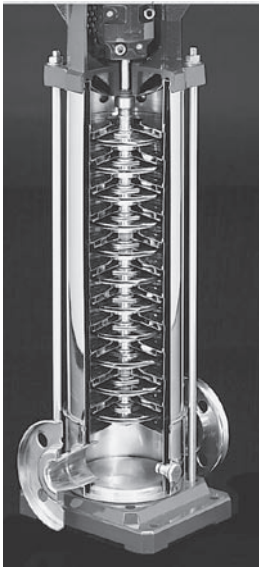

**In-line ANSI
flange connections**

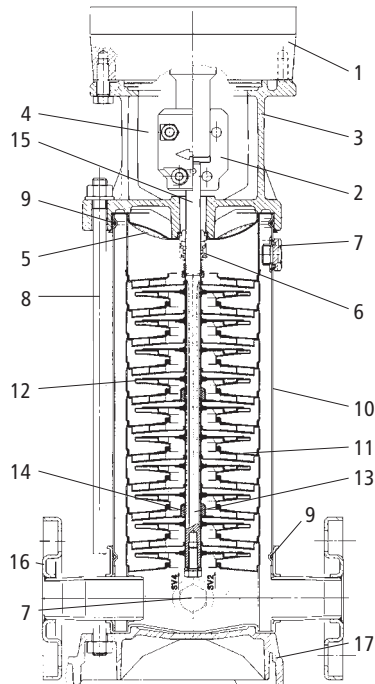

**Base Models: 1SV, 2SV, 3SV
and 4SV Major Components**

No.	Description	SVA, SVB, SVC (1, 2, 3 and 4 SSV Sizes)			SVD (1, 2, 3 and 4 SSV Sizes)		
		Material	ASTM	DIN	Material	ASTM	DIN
1	NEMA Vertical Motor						
2	Rigid Coupling	Aluminum	B85	AC46100	Aluminum	B85	AC46100
		Cast Iron	A48 Class 25	JL1030	Cast Iron	A48 Class 25	JL1030
3	Motor Adapter	Cast Iron	A48 Class 35	JL1040	Cast Iron	A48 Class 35	JL1040
4	Coupling Guard	Stainless Steel	A193-304	1.4301	Stainless Steel	A193-304	1.4301
5	Seal Housing	Stainless Steel	A193-304	1.4301	Stainless Steel	A193-316L	1.4404
6	Mechanical Seal	See Seal Materials Chart for Complete Details			See Materials Chart for Complete Details		
7	Plugs, Fill and Drain	Stainless Steel/O-Ring	A193-316	1.4401	Stainless Steel/O-Ring	A193-316	1.4401
8	Tie Rod	Zinc Plated Steel	B633	1.0765	Zinc Plated Steel	B633	1.0765
9	O-Ring, Sleeve	Viton (std) EPDM (opt)	B633		Viton (std) EPDM (opt)	B633	
10	Sleeve (casing)	Stainless Steel	A193-304	1.4301	Stainless Steel	A193-316L	1.4404
11	Diffuser	Stainless Steel	A193-316	1.4401	Stainless Steel	A193-316	1.4401
12	Impeller	Stainless Steel	A193-316	1.4401	Stainless Steel	A193-316	1.4401
13	Tungsten Carbide Sleeve	Tungsten Carbide			Tungsten Carbide		
14	Ceramic Bushing	Ceramic			Ceramic		
15	Shaft	Stainless Steel	A193-304	1.4301	Stainless Steel	A193-316	1.4401
16	Pump Body	Stainless Steel	A193-304	1.4301	Stainless Steel	A193-316L	1.4401
17	Pump Base	Aluminum	B85	AC46100	Aluminum	B85	AC46100

Base Model: 33SV, 46SV, 66SV and 92SV
Major Components

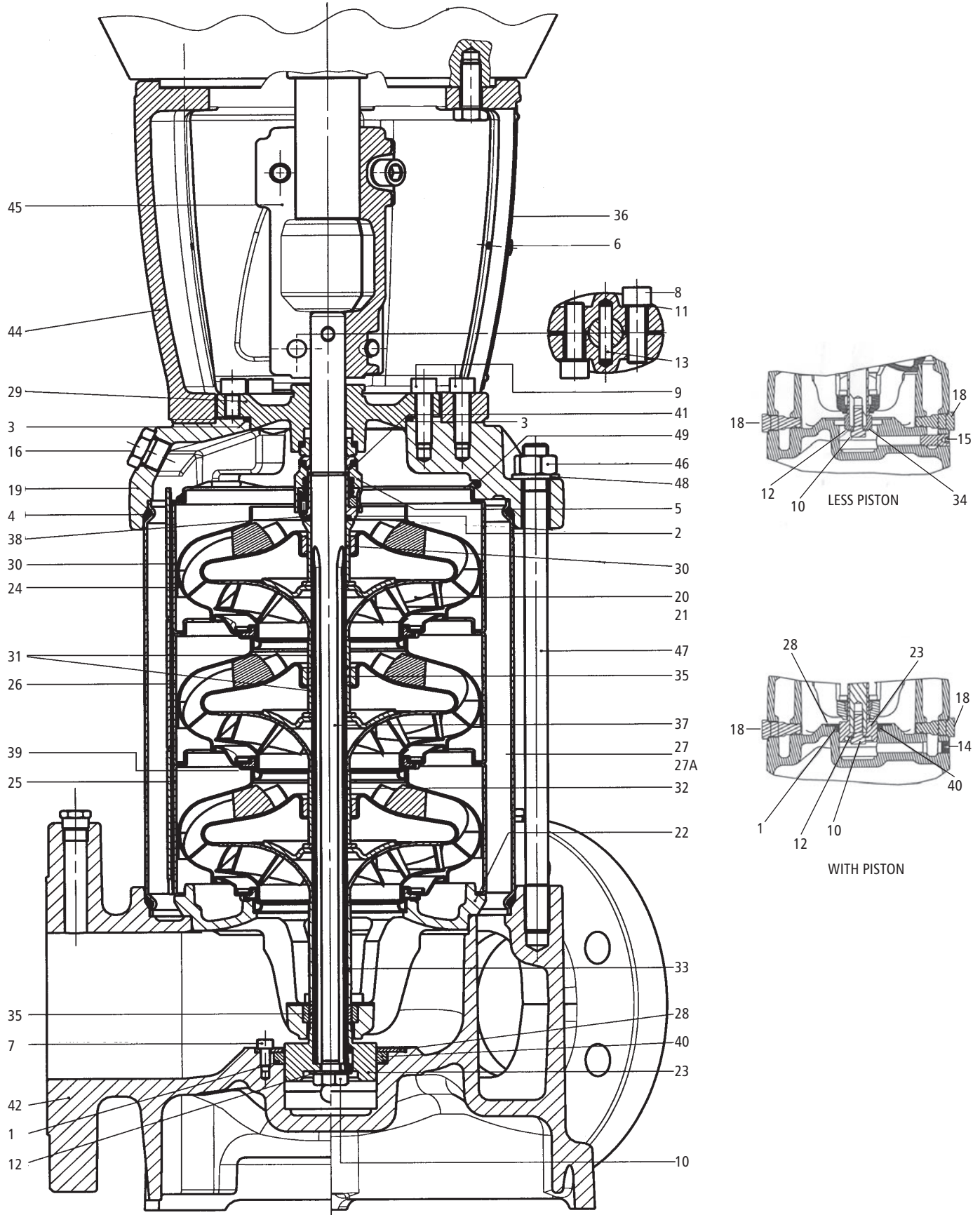

Base Model: 33SV, 46SV, 66SV and 92SV
Major Components

No.	Description	SVB (33 – 92SV)			SVD (33 – 92SV)		
		Material	ASTM	DIN	Material	ASTM	DIN
1	O-Ring, Piston Seal	Viton (std) EPDM (opt)			Viton (std) EPDM (opt)		
2	O-Ring, Mechanical Seal Sleeve	Viton (std) EPDM (opt)			Viton (std) EPDM (opt)		
3	O-Ring, Seal housing	Viton (std) EPDM (opt)			Viton (std) EPDM (opt)		
4	O-Ring, Sleeve	Viton (std) EPDM (opt)			Viton (std) EPDM (opt)		
5	Mechanical Seal	See Seal Materials Chart for Complete Detail			See Seal Materials Chart for Complete Details		
5A	Cartridge Seal (not shown)	See Seal Materials Chart for Complete Detail			See Seal Materials Chart for Complete Details		
6	Screw, Guard	Stainless Steel	A193-304	1.4301	Stainless Steel	A193-304	1.4301
7	Screw, Piston Holding Disc	Stainless Steel	A193-316	1.4401	Stainless Steel	A193-316	1.4401
8	Screw, Coupling	Zinc Plated Steel	B363		Zinc Plated Steel	B633	
9	Screw, MA and Seal Housing	Zinc Plated Steel	B633		Zinc Plated Steel	B633	
10	Screw, Impeller	Stainless Steel	A193-316	1.4401	Stainless Steel	A193-316	1.4401
11	Washer, Coupling	Carbon Steel	A108		Carbon Steel	A108	
12	Washer, Impeller	Stainless Steel	A193-316	1.4401	Stainless Steel	A193-316	1.4401
13	Pin, Coupling	Carbon Steel	A108		Carbon Steel	A108	
14	Plug, with Piston	Stainless Steel	A193-316	1.4401	Stainless Steel	A193-316	1.4401
15	Plug, without Piston	Stainless Steel	A193-316	1.4401	Stainless Steel	A193-316	1.4401
16	Plug, Fill	Stainless Steel/O-Ring	A193-316	1.4401	Stainless Steel/O-Ring	A193-316	1.4401
17	Plug, Vent (not shown)	Stainless Steel/O-Ring	A193-316	1.4401	Stainless Steel/O-Ring	A193-316	1.4401
18	Plug, Drain	Stainless Steel/O-Ring	A193-316	1.4401	Stainless Steel/O-Ring	A193-316	1.4401
19	Pump Head	Cast Iron	A48 Class 35	JL1030	Stainless Steel	316 CF8M	1.4408
20	Impeller, Full Diameter	Stainless Steel	A193-316L	1.4404	Stainless Steel	A193-316L	1.4404
21	Impeller, Reduced Diameter	Stainless Steel	A193-316L	1.4404	Stainless Steel	A193-316L	1.4404
22	Lower Bearing Assembly	SS/Cast Iron	A193-316L/A48 Class 35	1.4404/JL1030	Stainless Steel	A193-316L/316 CF8M	1.4404/1.4408
23	Piston	Dupless SS	A182-F51	1.4462	Dupless SS	A182-F51	1.4462
24	Diffuser, Final	Stainless Steel	A193-316L	1.4404	Stainless Steel	A193-316L	1.4404
25	Diffuser with Carbon Bushing	Stainless Steel	A193-316L	1.4404	Stainless Steel	A193-316L	1.4404
26	Diffuser with Tungsten Bushing	Stainless Steel	A193-316L	1.4404	Stainless Steel	A193-316L	1.4404
27	Outer Sleeve, 25 Bar	Stainless Steel	A193-316L	1.4404	Stainless Steel	A193-316L	1.4404
27A	Outer Sleeve, 40 Bar	Stainless Steel	A193-316L	1.4404	Stainless Steel	A193-316L	1.4404
28	Holding Disc, Piston Seal	Stainless Steel	A193-316L	1.4404	Stainless Steel	A193-316L	1.4404
29	Seal Housing	Cast Iron	A48 Class 35	JL1030	Stainless Steel	316 CF8M	1.4408
30	Spacer, Impeller Final	Stainless Steel	A193-316	1.4401	Stainless Steel	A193-316	1.4401
31	Spacer, Shaft Bushing	Stainless Steel	A193-316	1.4401	Stainless Steel	A193-316	1.4401
32	Spacer, Impeller	Stainless Steel	A193-316	1.4401	Stainless Steel	A193-316	1.4401
33	Spacer, Impeller Lower (66-92SV)	Stainless Steel	A193-316	1.4401	Stainless Steel	A193-316	1.4401
34	Bushing, Non-Piston	Stainless Steel	A193-316	1.4401	Stainless Steel	A193-316	1.4401
35	Tungsten Carbide Bushing	Tungsten Carbide			Tungsten Carbide		
36	Coupling Guard	Stainless Steel	A193-304	1.4301	Stainless Steel	304	1.4301
37	Shaft	Dupless SS	A182-F51	1.4462	Dupless SS	A183-F51	1.4462
38	Mechanical Seal Shaft Sleeve	Stainless Steel	A193-316	1.4401	Stainless Steel	A193-316	1.4401
39	Wear Ring, Impeller	PPS Glass Filled			PPS Glass Filled		
40	Piston Seal	Impregnated Carbon			Impregnated Carbon		
41	Stop Ring, Impeller	Stainless Steel	A193-316	1.4401	Stainless Steel	A193-316	1.4401
42	Pump Body	Cast Iron	A48 Class 35	JL1030	Stainless Steel	316 CF8M	1.4408
43	Motor Adapter Plate (not shown)	Cast Iron	A48 Class 25	JL1030	Cast Iron	A48 Class 25	JL1030
44	Motor Adapter	Cast Iron	A48 Class 25	JL1030	Cast Iron	A48 Class 25	JL1030
45	Coupling, Half	Cast Iron	A48 Class 25	JL1030	Cast Iron	A48 Class 25	JL1030
46	Nut, Tie-Rod	Zinc Plated Steel	B633		Zinc Plated Steel	B633	
47	Tie-Rod	Zinc Plated Steel	B633		Zinc Plated Steel	B633	
48	Washer, Tie-Rod	Zinc Plated Steel	B633		Zinc Plated Steel	B633	
49	Spring, Final Diffuser	Stainless Steel	A193-316	1.4401	Stainless Steel	A193-316	1.4401