

# Dimensions and Weights

## 4SV Series 3500 RPM

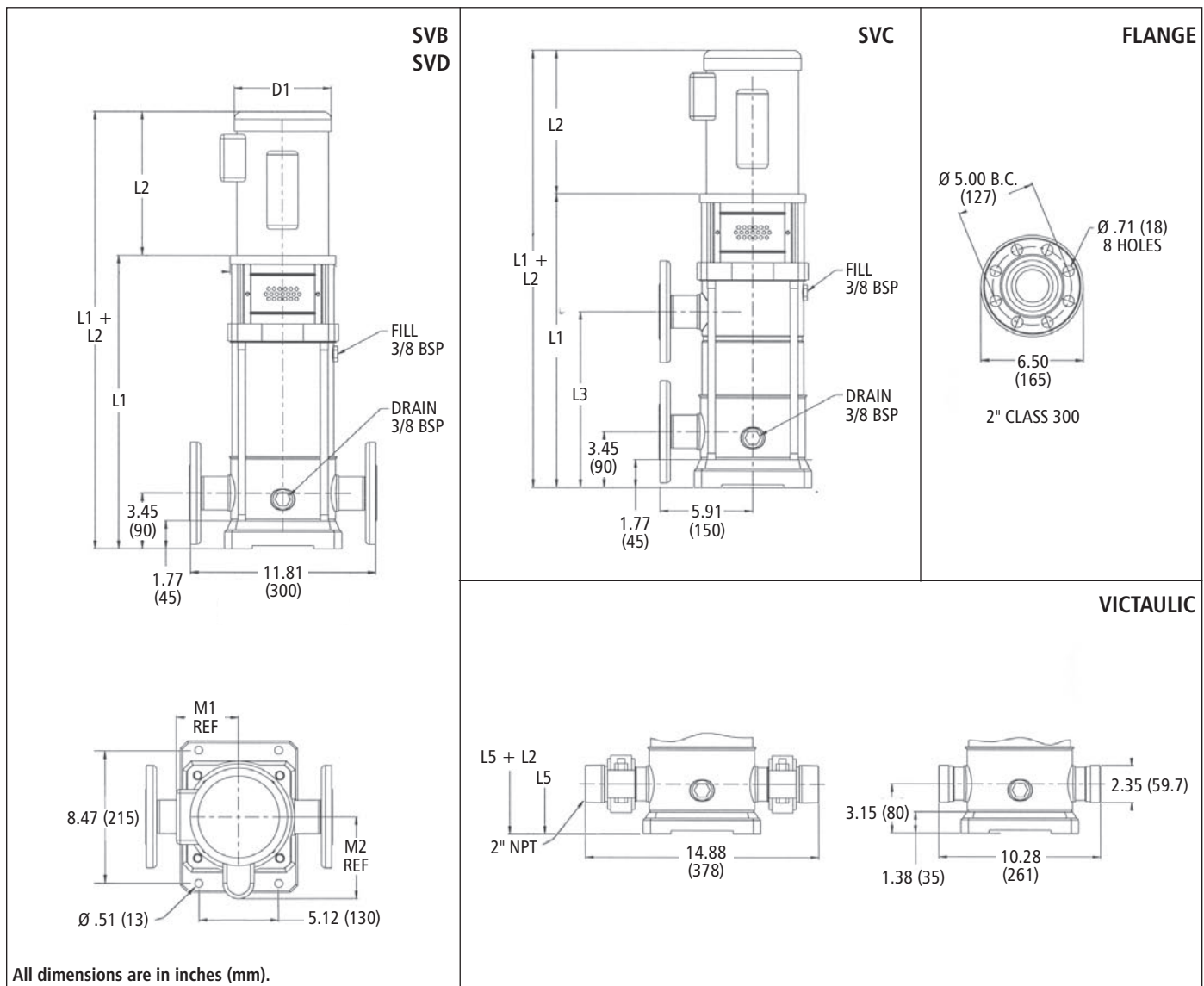

Stage	Frame (1-Phase)		Frame (3-Phase)		HP	L1	L2				M1 (ref.)	M2 (ref.)	D1 (max.)		Weights (lb)							
	ODP	TEFC	ODP	TEFC			ODP	TEFC	L3	L5			ODP	TEFC	Liquid End	ODP	TEFC					
2	182-4TC		182-4TC		5	15.75	13.94	15.44	15.75	17.25	6.88	6.63	8.50	8.50	33	75	85					
3	213TC				7½	17.25									35	101	124					
4					7½	18.75									39	101	124					
5			213TC	215TC	10	21.44	15.56	16.56	12.69	21.44	8.06	8.77	10.25	48	130	151						
6			215TC	254TC	15	24.44								15.69	24.44	9.25		10.19	10.31	50	128	250
7					15	24.44								15.69	24.44					52		
8			15	25.94	17.19	25.94	55															
9					254TC	256TC	20	28.88	20.19	28.88	65	220	280									
10					20	28.88							75	220	280							
12			256TC		25	31.88							11.63	79	240	300						

# 4SV Curve

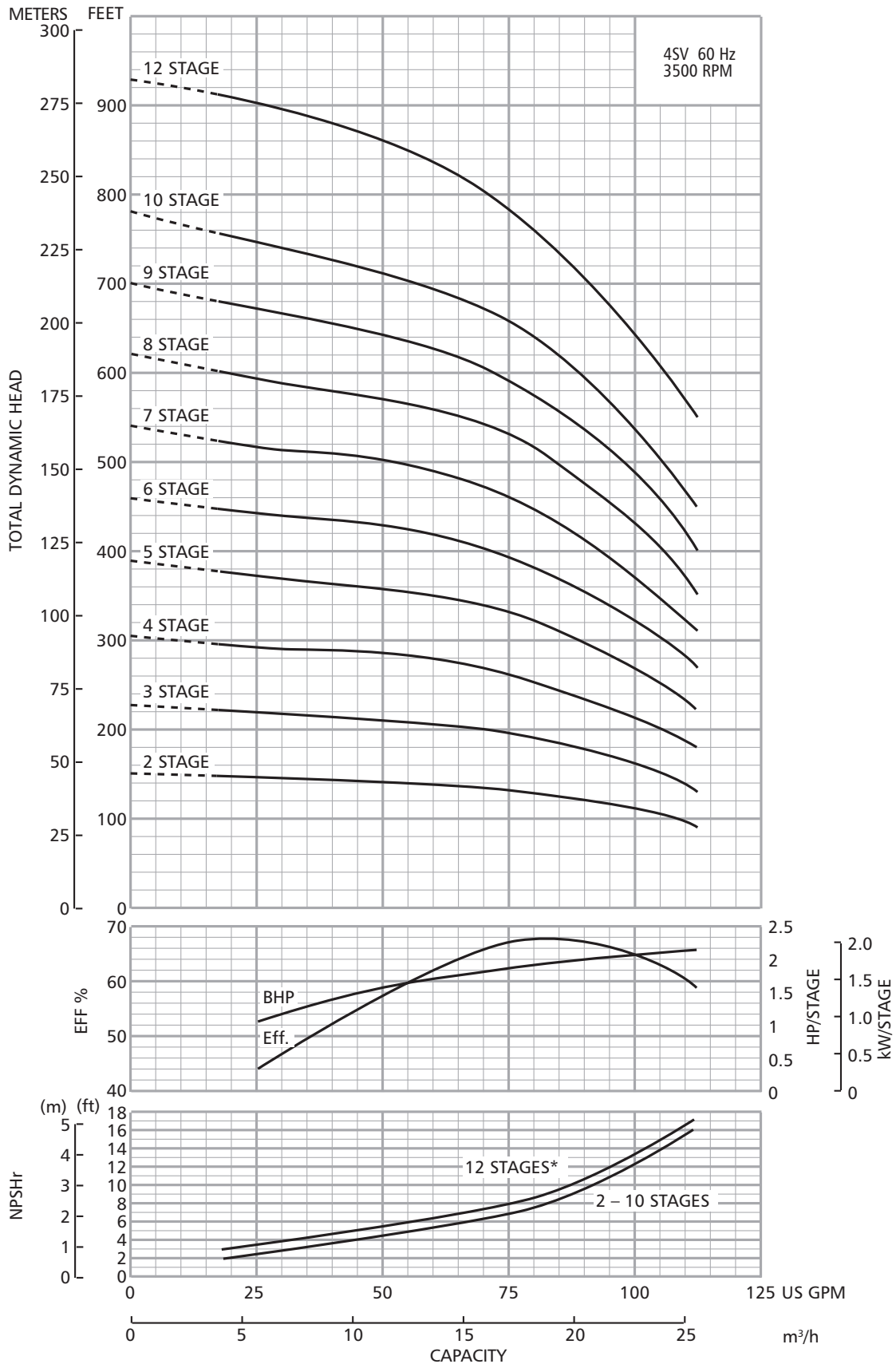

\* For vertical shaft installation only.