



**CR Series**

# CRN32

## Parts List & Kits

---

### Contents

- Parts List
- Spare Part Kits
- Accessories
- Special Tools
- Standard Tools
- Tools for Torques

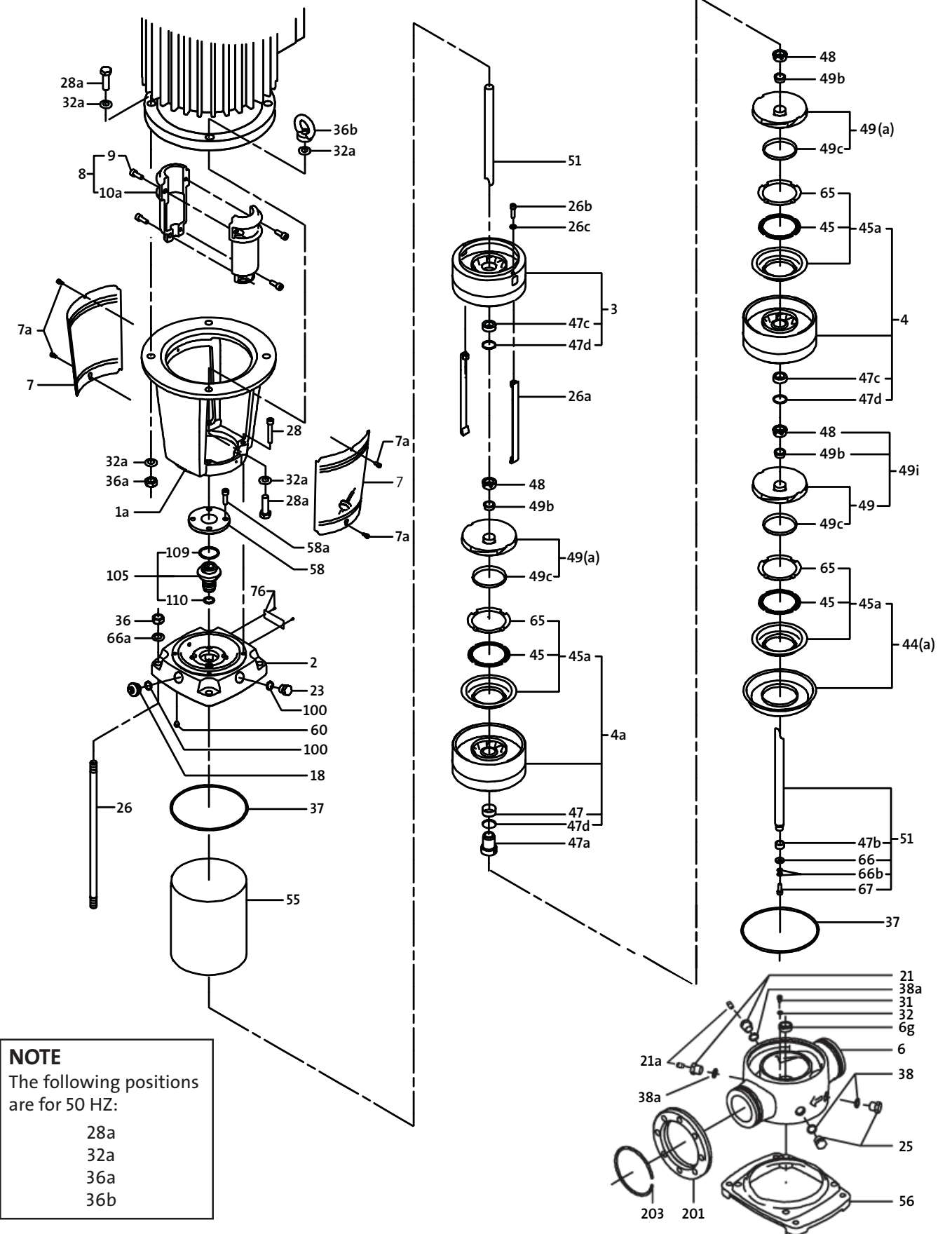

**NOTE**  
 The following positions  
 are for 50 HZ:  
 28a  
 32a  
 36a  
 36b

Parts List

| Pos. No. | Part Description                        | Model | Stages      | No. Used | Comments/Dimensions             | Material No. | Included in Kits? |
|----------|---|-------|-------------|----------|---------------------------------|--------------|-------------------|
|          | Cool Top™ (option)***                   |       | 1-1 to 11   | 1        |                                 | 290872       | No                |
|          | Bearing Flange (option)                 |       | 1-1 to 1    | 1        | NEMA 182/184                    | 350548       | No                |
|          |   |       | 1 to 3-2    | 1        | NEMA 213/215                    | 350549       | No                |
|          |   |       | 3 to 5      | 1        | NEMA 254/256                    | 370780       | No                |
|          |   |       | 5-2 to 11-2 | 1        | NEMA 284/286                    | 370781       | No                |
|          |   |       | 9-2 to 11-2 | 1        | NEMA 324...365                  | 370782       | No                |
|          | IEC Bearing Flange                      |       | 2-2 to 2    | 1        | MG 100/112, F130                | 350546       | No                |
|          |   |       | 3-2 to 4    | 1        | MG 132, F265                    | 350547       | No                |
|          |   |       | 5-2 to 12   | 1        | MG 160/180, F300                | 370777       | No                |
|          |   |       | 13-2 to 14  | 1        | MG 200, F350                    | 370778       | No                |
|          |   |       |             | 1        | MG 225, F400                    | 370779       | No                |
| 1a       | Motor Stool, LARCR                      |       | 1-1 to 3-2  | 1        | 182TC-215TC, 3-10 HP            | 370103       | No                |
|          |   |       | 3 to 4      | 1        | 254/256TC, 15 HP                | 370303       | No                |
|          |   |       | 5-2 to 11-2 | 1        | 284/286TSC, 20-40 HP            | 370104       | No                |
|          |   |       |             | 1        | 324/326/364SC, 50-60 HP         | 370140       | No                |
|          | IEC Motor Stool, LARCR                  |       | 1-1 to 1    | 1        | 1.5-2.2 kW                      | 370076       | No                |
|          |   |       | 2-2 to 2    | 1        | 3.0-4.0 kW                      | 370077       | No                |
|          |   |       | 3-2 to 4    | 1        | 5.5-7.5 kW                      | 370078       | No                |
|          |   |       | 5-2 to 12   | 1        | 11.0-22.0 kW                    | 370079       | No                |
|          |   |       | 13-2 to 14  | 1        | 30.0-37.0 kW                    | 370080       | No                |
|          |   |       |             | 1        | 45.0 kW                         | 370081       | No                |
| 2        | Pump Head                               |       | 1-1 to 14   | 1        | Stainless                       | 290060       | No                |
| 3        | Top Chamber CPL.                        |       | 1-1 to 14   | 1        | Graflon® Sleeve Bushing         | 290084       | No                |
|          | Top Chamber CPL. (option)               |       | 1-1 to 14   | 1        | PTFE Sleeve Bushing             | 290823       | No                |
| 4        | Chamber CPL.                            |       | 2-2 to 14   | AAA      | Graflon Sleeve Bushing          | 290407       | No                |
|          | Chamber CPL. (option)                   |       | 2-2 to 14   | AAA      | PTFE Sleeve Bushing             | 290822       | No                |
| 4a       | Chamber CPL. w/Bearing                  |       | 3-2 to 14   | AAAA     | Graflon Bearing Ring            | 290408       | No                |
|          | Chamber CPL. w/Bearing (option)         |       | 3-2 to 14   | AAAA     | SIC Bearing Ring/PTFE Neck Ring | 290827       | No                |
| 6        | Base                                    |       | 1-1 to 14   | 1        | Stainless                       | 290004       | No                |
|          | Base (Victaulic type / PJE option)      |       | 1-1 to 14   | 1        | Stainless, 3.0" (Ø88.2mm)       | 290894       | No                |
| 6g       | Stationary Bottom Bearing Ring for Base |       | 1-1 to 14   | 1        | Tungsten Carbide                | 370130       | YES               |
| 7        | Coupling Guard                          |       |             | 2        | 182-215TC, 3-10 HP/1.5-7.5 kW   | 370178       | No                |
|          |   |       |             | 2        | 254-365TS, 15-60 HP/11.0-45 kW  | 370173       | No                |
| 7a       | Screw for Coupling Guard                |       | 1-1 to 14   | 4        | M5 x 10mm                       | 96406306     | No                |
| 8        | Coupling CPL. w/Pos.9                   |       | 1-1 to 1    | 1        | 182/184TC, 3-5 HP               | 370724       | YES               |
|          |   |       | 2-2 to 3-2  | 1        | 213/215TC, 7 1/2-10 HP          | 370725       | YES               |
|          |   |       | 3 to 11-2   | 1        | 254-286TSC, 15-40 HP            | 370715       | YES               |
|          |   |       |             | 1        | 324-365TS, 50-60 HP             | 370716       | YES               |
|          | IEC Coupling CPL. w/Pos.9               |       | 1-1 to 1    | 1        | 1.5-2.2 kW                      | 370703       | YES               |
|          |   |       | 2-2 to 2    | 1        | 3.0-4.0 kW                      | 370704       | YES               |
|          |   |       | 3-2 to 4    | 1        | 5.5-7.5 kW                      | 370710       | YES               |
|          |   |       | 5-2 to 10   | 1        | 11.0-18.5 kW                    | 370035       | YES               |
|          |   |       | 11-2 to 12  | 1        | 22.0 kW                         | 370036       | YES               |
|          |   |       | 13-2 to 14  | 1        | 30.0-37.0 kW                    | 370037       | YES               |
| 9        | Allen Screw                             |       | 1-1 to 14   | 4        | M10 x 25mm                      | 00ID7901     | YES               |
| 18       | Priming/ Vent Plug                      |       | 1-1 to 14   | 1        | G 1/2A                          | 405150       | No                |
| 21       | Drain Plug                              |       | 1-1 to 14   | 2        | G 1/2A w/ 1/4" NPT              | 91120659     | No                |
| 21a      | Pipe Plug                               |       | 1-1 to 14   | 2        | 1/4" NPT SS SQHD                | 00ID7216     | No                |
| 23 & 25  | Drain Plug                              |       | 1-1 to 14   | 3        | G 1/2A                          | 370025       | No                |
| 26       | Staybolt                                |       | 1-1 to 1    | 4        | M16 x 282mm                     | 290231       | No                |
|          |   |       | 2-2 to 2    | 4        | M16 x 352mm                     | 290232       | No                |
|          |   |       | 3-2 to 3    | 4        | M16 x 422mm                     | 290233       | No                |
|          |   |       | 4-2 to 4    | 4        | M16 x 492mm                     | 290234       | No                |
|          |   |       | 5-2 to 5    | 4        | M16 x 562mm                     | 290235       | No                |
|          |   |       | 6-2 to 6    | 4        | M16 x 632mm                     | 290236       | No                |
|          |   |       | 7-2 to 7    | 4        | M16 x 702mm                     | 290237       | No                |
|          |   |       | 8-2 to 8    | 4        | M16 x 772mm                     | 290238       | No                |
|          |   |       | 9-2 to 9    | 4        | M16 x 842mm                     | 290239       | No                |
|          |   |       | 10-2 to 10  | 4        | M16 x 912mm                     | 290240       | No                |
|          |   |       | 11-2 to 11  | 4        | M16 x 982mm                     | 290241       | No                |
|          |   |       | 12-2 to 12  | 4        | M16 x 1052mm                    | 290242       | No                |
|          |   |       | 13-2 to 13  | 4        | M16 x 1122mm                    | 290243       | No                |
|          |   |       | 14-2 to 14  | 4        | M16 x 1192mm                    | 290244       | No                |

Due to part changes over time, all position numbers (1-203) may not be used.

This column indicates which pump model uses the spare part. If blank, the part is used in all models.

\*20 HP, 575V motor has a 284 TSC; 40 HP, 575V motor has a 324 TSZ.

\*\*\*Retro-fitting a Cool Top™ to a standard CR(N)32/CR(N)45 requires three stage longer shafts, stay bolts, along with option\*\*\* components.

NOTE: Graflon® is a registered trademark of Morganite.

Parts List

| Pos. No.  | Part Description                            | Model | Stages      | No. Used  | Comments/Dimensions      | Material No. | Included in Kits? |
|-----------|---|-------|-------------|-----------|--------------------------|--------------|-------------------|
| 26a       | Strap                                       |       | 1-1 to 1    | 2         | M8 x 79mm                | 290336       | No                |
|           |   |       | 2-2 to 2    | 2         | M8 x 149mm               | 290337       | No                |
|           |   |       | 3-2 to 3    | 2         | M8 x 219mm               | 290338       | No                |
|           |   |       | 4-2 to 4    | 2         | M8 x 289mm               | 290339       | No                |
|           |   |       | 5-2 to 5    | 2         | M8 x 359mm               | 290340       | No                |
|           |   |       | 6-2 to 6    | 2         | M8 x 429mm               | 290341       | No                |
|           |   |       | 7-2 to 7    | 2         | M8 x 499mm               | 290342       | No                |
|           |   |       | 8-2 to 8    | 2         | M8 x 569mm               | 290343       | No                |
|           |   |       | 9-2 to 9    | 2         | M8 x 639mm               | 290344       | No                |
|           |   |       | 10-2 to 10  | 2         | M8 x 709mm               | 290345       | No                |
|           |   |       | 11-2 to 11  | 2         | M8 x 779mm               | 290346       | No                |
|           |   |       | 12-2 to 12  | 2         | M8 x 849mm               | 290347       | No                |
|           |   |       | 13-2 to 13  | 2         | M8 x 919mm               | 290348       | No                |
|           |   |       | 14-2 to 14  | 2         | M8 x 989mm               | 290349       | No                |
| 26b       | Allen Screw for Strap                       |       | 1-1 to 14   | 2         | M8 x 30mm                | 96406258     | No                |
| 26c       | Washer for Strap                            |       | 1-1 to 14   | 2         | Ø16 / Ø8.4 x 1.6mm       | 00ID3284     | No                |
| 28        | Allen Screw for Pump Head                   |       | 1-1 to 14   | 4         | M10 x 50mm               | 96406305     | No                |
| 28a       | Motor Bolt                                  |       | 1-1 to 11-2 | 4         | 1/2" x 13 UNC, 3-40 HP   | 96026055     | No                |
|           |   |       |             | 4         | 5/8" x 11UNC, 50-60 HP   | 96026056     | No                |
|           | IEC Motor Bolt                              |       | 1-1 to 2    | 4         | M8 x 20mm, 1.5-4.0 kW    | 00ID8024     | No                |
|           |   |       | 3-2 to 4    | 4         | M12 x 40mm, 5.5-7.5 kW   | 00ID7913     | No                |
|           |   |       | 5-2 to 14   | 4         | M16 x 45mm, 11.0-45.0 kW | 00ID7905     | No                |
| 31        | Allen Screw for Pos. 6g                     |       | 1-1 to 14   | 1         | M6 x 10mm                | 96406261     | YES               |
| 32        | Washer for Pos.31                           |       | 1-1 to 14   | 1         | Ø12.5/ Ø6.4 x 1.6mm      | 00ID3819     | YES               |
| 32a       | Washer for IEC Pos.28a & 36a (b)            |       | 1-1 to 4    | 8         | Ø24/ Ø13 x 2.5mm         | 96430377     | No                |
|           |   |       | 5-2 to 14   | 8         | Ø30/ Ø17 x 1.6mm         | 96430378     | No                |
| 36        | Staybolt Nut                                |       | 1-1 to 14   | 4         | RR M16                   | 00ID2792     | No                |
| 36a       | Nut for IEC Pos. 28a                        |       | 3-2 to 4    | 2         | M12, 5.5-7.5 kW          | 00ID7917     | No                |
|           |   |       | 5-2 to 14   | 2         | M16, 11.0-45.0 kW        | 00ID7908     | No                |
| 36b       | Eye Nut for IEC Pos. 28a                    |       | 1-1 to 4    | 2         | M12, 5.5-7.5 kW          | 96428759     | No                |
|           |   |       | 5-2 to 14   | 2         | M16, 11.0-45.0 kW        | 96428760     | No                |
| 37        | Sleeve O-ring                               |       | 1-1 to 14   | 2         | EPDM, Ø197x4mm           | 96408403     | YES               |
|           |   |       | 1-1 to 14   | 2         | FKM, Ø197x4mm            | 96408405     | YES               |
|           | Sleeve O-ring (option)                      |       | 1-1 to 14   | 2         | FKM/PTFE, Ø197x4mm       | 96428155     | No                |
|           | Sleeve O-ring (option***)                   |       | 1-1 to 14   | 2         | FKM, Ø197x4mm            | 96442837     | No                |
| 38 & 38a  | Drain Plug O-ring                           |       | 1-1 to 14   | 4         | EPDM, Ø16.3 x 2.4mm      | 00ID1288     | YES               |
|           |   |       | 1-1 to 14   | 4         | FKM, Ø16.3 x 2.4mm       | 00ID2231     | YES               |
|           | Drain Plug O-ring (option)                  |       | 1-1 to 14   | 4         | NBR, Ø16.3 x 2.4mm       | 00ID7035     | No                |
|           | Drain Plug O-ring (option)                  |       | 1-1 to 14   | 4         | FFKM, Ø16.3 x 2.4mm      | 96428162     | No                |
|           | Drain Plug O-ring (option***)               |       | 1-1 to 14   | 2         | FKM, Ø16.3 x 2.4mm       | 96442869     | No                |
| 44        | Inlet Base Interface                        |       | 1-1 to 14   | 1         | ACOFLO 215 Neck Ring     | 290409       | No                |
|           | Inlet Base Interface CPL. (option)          |       | 1-1 to 14   | 1         | PTFE Neck Ring           | 290825       | No                |
| 44a       | Inlet Base Interface CPL. (Low NPSH option) |       | 1-1 to 14   | 1         | ACOFLO 215 Neck Ring     | 290885       | No                |
| 45        | Neck Ring                                   |       | 1-1 to 14   | # stg.    | ACOFLO 215               | 290091       | YES               |
|           | Neck Ring (option)                          |       | 1-1 to 14   | # stg.    | PTFE Neck Ring           | 290051       | No                |
| 45a       | Neck Ring CPL.                              |       | 1-1 to 14   | # stg.    | ACOFLO 215 Neck Ring     | 290078       | No                |
| 45b       | Neck Ring CPL. (Low NPSH)                   |       | 1-1 to 14   | # stg.    | ACOFLO 215 Neck Ring     | 350068       | No                |
| 47        | Chamber Bearing Ring                        |       | 3-2 to 14   | AAAA      | Graflon, 30mm            | 370214       | YES               |
|           | Chamber Bearing Ring (option)               |       | 3-2 to 14   | AAAA      | SIC, 30mm                | 370096       | No                |
| 47a       | Intermediate Bearing with Driver            |       | 3-2 to 14   | AAAA      | Tungsten Carbide         | 290065       | YES               |
| 47b       | Bottom Bearing for Shaft                    |       | 1-1 to 14   | 1         | Tungsten Carbide         | 370069       | YES               |
| 47c       | Chamber Sleeve Bushing                      |       | 1-1 to 14   | AAAAA     | Graflon, Ø22mm           | 370024       | YES               |
|           | Chamber Sleeve Bushing (option)             |       | 1-1 to 14   | AAAAA     | PTFE, Ø22mm              | 370094       | No                |
| 47d & 47e | Lock Ring for Bearing Ring/Sleeve Bushing   |       | 1-1 to 14   | AAAAA     |                          | 370213       | YES               |
| 48        | Split Cone Nut                              |       | 1-1 to 14   | # stg.    | M30, Delta Seal          | 370098       | No                |
| 49        | Impeller Full Dia. w/Pos. 49c               |       | 1 to 14     | # stg.●●● |                          | 290075       | No                |
| 49a       | Impeller Reduced Dia. w/Pos.49c             |       | 1-1 to 14-2 | ●●●       |                          | 290114       | No                |
| 49b       | Split Cone                                  |       | 1-1 to 14   | # stg.    |                          | 370019       | No                |
| 49c       | Wear Ring for Impeller                      |       | 1-1 to 14   | # stg.    |                          | 290049       | YES               |
| 49i       | Impeller Low NPSH w/Pos. 48, 49b,c          |       | 1-1 to 14-2 | 1         |                          | 290873       | No                |
| 51        | Shaft CPL. (Includes Pos.47b, 66, 66b, 67)  |       | 1-1 to 1    | 1         | Ø22 x 320mm              | 290186       | No                |
|           |   |       | 2-2 to 2    | 1         | Ø22 x 390mm              | 290187       | No                |
|           |   |       | 3-2 to 3    | 1         | Ø22 x 460mm              | 290188       | No                |
|           |   |       | 4-2 to 4    | 1         | Ø22 x 530mm              | 290189       | No                |
|           |   |       | 5-2 to 5    | 1         | Ø22 x 600mm              | 290190       | No                |
|           |   |       | 6-2 to 6    | 1         | Ø22 x 670mm              | 290191       | No                |
|           |   |       | 7-2 to 7    | 1         | Ø22 x 740mm              | 290192       | No                |

(continued)

Due to part changes over time, all position numbers (1-203) may not be used.

This column indicates which pump model uses the spare part. If blank, the part is used in all models.

(option\*\*\*) These components are used in the lower / hot section of Cool Top™ equipped pumps.

Parts List

| Pos. No.   | Part Description                     | Model                         | Stages     | No. Used     | Comments/Dimensions           | Material No. | Included in Kits? |         |        |    |
|------------|--------------------------------------|-------------------------------|------------|--------------|-------------------------------|--------------|-------------------|---------|--------|----|
| 51         | Shaft CPL. (continued)               |                               | 8-2 to 8   | 1            | Ø22 x 810mm                   | 290193       | No                |         |        |    |
|            |                                      |                               | 9-2 to 9   | 1            | Ø22 x 880mm                   | 290194       | No                |         |        |    |
|            |                                      |                               | 10-2 to 10 | 1            | Ø22 x 950mm                   | 290195       | No                |         |        |    |
|            |                                      |                               | 11-2 to 11 | 1            | Ø22 x 1020mm                  | 290196       | No                |         |        |    |
|            |                                      |                               | 12-2 to 12 | 1            | Ø22 x 1090mm                  | 290197       | No                |         |        |    |
|            |                                      |                               | 13-2 to 13 | 1            | Ø22 x 1160mm                  | 290198       | No                |         |        |    |
|            |                                      |                               | 14-2 to 14 | 1            | Ø22 x 1230mm                  | 290199       | No                |         |        |    |
|            |                                      |                               | 55         | Outer Sleeve |                               | 1-1 to 1     | 1                 | 95.5mm  | 290216 | No |
|            |                                      |                               |            |              |                               | 2-2 to 2     | 1                 | 165.5mm | 290217 | No |
|            |                                      |                               |            |              |                               | 3-2 to 3     | 1                 | 235.5mm | 290218 | No |
|            |                                      |                               |            |              |                               | 4-2 to 4     | 1                 | 305.5mm | 290219 | No |
|            |                                      |                               |            |              |                               | 5-2 to 5     | 1                 | 375.5mm | 290220 | No |
|            |                                      |                               |            |              |                               | 6-2 to 6     | 1                 | 445.5mm | 290523 | No |
|            |                                      |                               |            |              |                               | 7-2 to 7     | 1                 | 515.5mm | 290524 | No |
| 8-2 to 8   | 1                                    | 585.5mm                       |            |              |                               | 290223       | No                |         |        |    |
| 9-2 to 9   | 1                                    | 655.5mm                       |            |              |                               | 290224       | No                |         |        |    |
| 10-2 to 10 | 1                                    | 725.5mm                       |            |              |                               | 290225       | No                |         |        |    |
| 11-2 to 11 | 1                                    | 795.5mm                       |            |              |                               | 290226       | No                |         |        |    |
| 12-2 to 12 | 1                                    | 865.5mm                       |            |              |                               | 290227       | No                |         |        |    |
| 13-2 to 13 | 1                                    | 935.5mm                       |            |              |                               | 290228       | No                |         |        |    |
| 14-2 to 14 | 1                                    | 1005.5mm                      |            |              |                               | 290229       | No                |         |        |    |
| 56         | Base Plate for G model               |                               | 1-1 to 14  | 1            | Cast Iron                     | 290035       | No                |         |        |    |
|            | Base Plate for GI model              |                               | 1-1 to 14  | 1            | Stainless                     | 290036       | No                |         |        |    |
| 58         | Seal Carrier                         |                               | 1-1 to 14  | 1            |                               | 980927       | No                |         |        |    |
| 58a        | Allen Screw                          |                               | 1-1 to 14  | 4            | M10 x 25mm                    | 96406407     | No                |         |        |    |
| 60         | Stack Compression Spring             |                               | 1-1 to 14  | 4            | EPDM                          | 370175       | YES               |         |        |    |
|            |                                      |                               | 1-1 to 14  | 4            | FKM                           | 370209       | YES               |         |        |    |
|            | Stack Compression Spring (option***) |                               | 1-1 to 14  | 4            | PTFE                          | 370796       | No                |         |        |    |
| 65         | Neck Ring Retainer                   |                               | 1-1 to 14  | # stg.       |                               | 290059       | YES               |         |        |    |
|            |                                      |                               | 1-1 to 14  | 1            |                               | 370212       | YES               |         |        |    |
| 66         | Washer for Shaft Bearing, Pos. 47b   |                               | 1-1 to 14  | 4            | Ø30/Ø17x3mm                   | 96430378     | No                |         |        |    |
| 66a        | Washer for Staybolt                  |                               | 1-1 to 14  | 2            |                               | 96417297     | YES               |         |        |    |
| 66b        | Lock Washer for Shaft Bearing        |                               | 1-1 to 14  | 1            |                               | 96406259     | YES               |         |        |    |
| 67         | Allen Screw for Shaft Bearing        |                               | 1-1 to 14  | 1            | M8 x 16mm                     | 981417       | No                |         |        |    |
| 76         | Name Plate                           |                               | 1-1 to 14  | 2            | Name Tag                      | 96022882     | No                |         |        |    |
| 76a        | Rivet for Name Plate                 |                               | 1-1 to 14  | 2            | 304SS, 3 x 5mm                | 00ID1288     | YES               |         |        |    |
| 100        | Drain Plug O-ring                    |                               | 1-1 to 14  | 2            | EPDM, Ø16.3 x 2.4mm           | 00ID2231     | YES               |         |        |    |
|            |                                      |                               | 1-1 to 14  | 2            | FKM, Ø16.3 x 2.4mm            | 00ID7035     | No                |         |        |    |
|            |                                      |                               | 1-1 to 14  | 2            | NBR, Ø16.3 x 2.4mm            | 96428162     | No                |         |        |    |
|            |                                      |                               | 1-1 to 14  | 2            | FFKM, Ø16.3 x 2.4mm           | 96442869     | No                |         |        |    |
|            |                                      |                               | 1-1 to 14  | 2            | EPDM                          | 985918       | YES               |         |        |    |
|            |                                      |                               | 1-1 to 14  | 2            | FKM                           | 985919       | YES               |         |        |    |
|            |                                      |                               | 1-1 to 14  | 2            | EPDM                          | 985920       | YES               |         |        |    |
|            |                                      |                               | 1-1 to 14  | 2            | FKM                           | 985921       | YES               |         |        |    |
|            |                                      |                               | 1-1 to 14  | 2            | EPDM                          | 985922       | YES               |         |        |    |
|            |                                      |                               | 1-1 to 14  | 2            | FKM                           | 985923       | YES               |         |        |    |
|            |                                      |                               | 1-1 to 14  | 2            | EPDM                          | 985927       | YES               |         |        |    |
|            |                                      |                               | 1-1 to 14  | 2            | FKM                           | 985928       | YES               |         |        |    |
|            |                                      |                               | 1-1 to 14  | 2            | EPDM                          | 985940       | YES               |         |        |    |
|            |                                      |                               | 1-1 to 14  | 2            | FKM                           | 985941       | YES               |         |        |    |
| 105        | Shaft Seal EUHE                      |                               | 1-1 to 14  | 1            | FFKM                          | 985952       | No                |         |        |    |
|            |                                      |                               | 1-1 to 14  | 1            | SIC/SIC, EPDM                 | 985950       | No                |         |        |    |
|            |                                      |                               | 1-1 to 14  | 1            | SIC/SIC, FKM                  | 985951       | No                |         |        |    |
|            |                                      |                               | 1-1 to 14  | 1            | SIC/SIC, Hasteloy Spring, FKM | 96467223     | No                |         |        |    |
|            |                                      |                               | 1-1 to 14  | 1            | SIC/SIC, FFKM                 | 985953       | No                |         |        |    |
|            |                                      |                               | 1-1 to 14  | 1            | FFKM                          | 985932       | No                |         |        |    |
|            |                                      |                               | 1-1 to 14  | 1            | NBR                           | 985936       | No                |         |        |    |
|            |                                      |                               | 1-1 to 14  | 1            | NBR                           | 985937       | No                |         |        |    |
|            |                                      |                               | 1-1 to 14  | 1            | EPDM                          | 985939       | No                |         |        |    |
|            |                                      |                               | 1-1 to 14  | 1            | SIC/SIC, EPDM                 | 985934       | No                |         |        |    |
|            |                                      |                               | 1-1 to 14  | 1            | SIC/SIC, FKM                  | 985935       | No                |         |        |    |
|            |                                      |                               | 1-1 to 14  | 1            | SIC/SIC, FFKM                 | 985948       | No                |         |        |    |
|            |                                      |                               | 1-1 to 14  | 1            | EPDM                          | 985918       | YES               |         |        |    |
|            |                                      |                               | 1-1 to 14  | 1            | FKM                           | 985919       | YES               |         |        |    |
| 1-1 to 14  | 1                                    | EPDM                          | 985920     | YES          |                               |              |                   |         |        |    |
| 1-1 to 14  | 1                                    | FKM                           | 985921     | YES          |                               |              |                   |         |        |    |
| 1-1 to 14  | 1                                    | EPDM                          | 985922     | YES          |                               |              |                   |         |        |    |
| 1-1 to 14  | 1                                    | FKM                           | 985923     | YES          |                               |              |                   |         |        |    |
| 1-1 to 14  | 1                                    | EPDM                          | 985927     | YES          |                               |              |                   |         |        |    |
| 1-1 to 14  | 1                                    | FKM                           | 985928     | YES          |                               |              |                   |         |        |    |
| 1-1 to 14  | 1                                    | EPDM                          | 985940     | YES          |                               |              |                   |         |        |    |
| 1-1 to 14  | 1                                    | FKM                           | 985941     | YES          |                               |              |                   |         |        |    |
| 1-1 to 14  | 1                                    | FFKM                          | 985952     | No           |                               |              |                   |         |        |    |
| 1-1 to 14  | 1                                    | SIC/SIC, EPDM                 | 985950     | No           |                               |              |                   |         |        |    |
| 1-1 to 14  | 1                                    | SIC/SIC, FKM                  | 985951     | No           |                               |              |                   |         |        |    |
| 1-1 to 14  | 1                                    | SIC/SIC, Hasteloy Spring, FKM | 96467223   | No           |                               |              |                   |         |        |    |
| 1-1 to 14  | 1                                    | SIC/SIC, FFKM                 | 985953     | No           |                               |              |                   |         |        |    |
| 1-1 to 14  | 1                                    | FFKM                          | 985932     | No           |                               |              |                   |         |        |    |
| 1-1 to 14  | 1                                    | NBR                           | 985936     | No           |                               |              |                   |         |        |    |
| 1-1 to 14  | 1                                    | NBR                           | 985937     | No           |                               |              |                   |         |        |    |
| 1-1 to 14  | 1                                    | EPDM                          | 985939     | No           |                               |              |                   |         |        |    |
| 1-1 to 14  | 1                                    | SIC/SIC, EPDM                 | 985934     | No           |                               |              |                   |         |        |    |
| 1-1 to 14  | 1                                    | SIC/SIC, FKM                  | 985935     | No           |                               |              |                   |         |        |    |
| 1-1 to 14  | 1                                    | SIC/SIC, FFKM                 | 985948     | No           |                               |              |                   |         |        |    |

Parts List

| Pos. No. | Part Description                     | Model | Stages    | No. Used                      | Comments/Dimensions   | Material No. | Included in Kits? |
|----------|--------------------------------------|-------|-----------|-------------------------------|-----------------------|--------------|-------------------|
| 105      | Shaft Seal KUHE (option) (continued) |       | 1-1 to 14 | 1                             | EPDM                  | 985942       | YES               |
|          |                                      |       | 1-1 to 14 | 1                             | FKM                   | 985943       | YES               |
|          |                                      |       | 1-1 to 14 | 1                             | EPDM                  | 985944       | YES               |
|          |                                      |       | 1-1 to 14 | 1                             | FKM                   | 985945       | YES               |
|          |                                      |       | 1-1 to 14 | 1                             | EPDM                  | 985946       | YES               |
|          |                                      |       | 1-1 to 14 | 1                             | FKM                   | 985947       | YES               |
|          |                                      |       | 1-1 to 14 | 1                             | EPDM, Ø44.45 x 3.53mm | 96407726     | YES               |
| 109      | Large O-ring for Seal                |       | 1-1 to 14 | 1                             | FKM, Ø44.45 x 3.53mm  | 96411713     | YES               |
|          |                                      |       | 1-1 to 14 | 1                             | EPDM, Ø21.2 x 3.55mm  | 96407724     | YES               |
| 109a & b | Connecting Pipe O-ring for Cool Top™ |       | 1-1 to 11 | 2                             | FKM, Ø44.45 x 3.53mm  | 96442849     | No                |
|          |                                      |       | 1-1 to 14 | 1                             | EPDM, Ø21.2 x 3.55mm  | 96407724     | YES               |
| 110      | O-ring for Seal                      |       | 1-1 to 14 | 1                             | FKM, Ø21.2 x 3.55mm   | 96411711     | YES               |
|          |                                      |       | 2         | ANSI B16.5 Class 150 - 2.5"   | 290026                | No           |                   |
|          |                                      |       | 2         | ANSI B16.5 Class 300 - 2.5"   | 290027                | No           |                   |
|          |                                      |       | 2         | ANSI B16.5 Class 150 - 3"     | 290011                | No           |                   |
|          |                                      |       | 2         | ANSI B16.5 Class 300 - 3"     | 290012                | No           |                   |
|          |                                      |       | 2         | ANSI B16.5 Class 150 - 2.5" N | 290007                | No           |                   |
|          |                                      |       | 2         | ANSI B16.5 Class 300 - 2.5" N | 290008                | No           |                   |
| 201      | Flange                               |       | 2         | ANSI B16.5 Class 150 - 3" N   | 290009                | No           |                   |
|          |                                      |       | 2         | ANSI B16.5 Class 300 - 3" N   | 290010                | No           |                   |
|          |                                      |       | 2         | Ø6/Ø108mm                     | 290030                | No           |                   |
| 203      | Lock Ring for Flange                 |       |           | 2                             |                       |              | No                |

Due to part changes over time, all position numbers (1-203) may not be used.

This column indicates which pump model uses the spare part. If blank, the part is used in all models.

NOTES:

- \*\* 8 stage or less 60 Hz, 12 stage or less 50 Hz
- \*\*\* 9 stage and up 60 Hz, 13 stage and up 50 Hz
- \*\*\*\* For working pressure over 360 PSI with inlet pressure not exceeding recommended maximum. Seal maximum working PSI is 580.
- ^^^^ 1 to 2 stage, 0 per unit
- ^^^^ 3 to 7 stage, 1 per unit
- ^^^^ 8 to 14 stage, 2 per unit
- ^^^^ Same as ^^^ plus 1
- ^^^ 1 stage, 0 per unit
- ^^^ 2 to 3 stage, 1 per unit
- ^^^ 4 to 7 stage, # of stages less 2
- ^^^ 8 to 14 stage, # of stages less 3
- In pump models with a - after the # of stages, the - # indicates the number of reduced impellers. Example: CRN32-6-2 (has 4 full size impellers, 2 reduced size impellers)

Key to Symbols

- KITS** ..... Recommended spare part
- Ø ..... Diameter
- ANSI** ..... American National Standards Institute
- CPL** ..... Complete Assembly – these parts consist of more than one component
- EPDM** ..... Ethylene Propylene (also known as EPR and EPT) – an elastic substance similar to rubber
- FFKM** ..... Kalrez Elastomer made by DuPont®
- FKM** ..... Fluoro Elastomer (generic for Viton®)
- FXM** ..... Fluoraz Elastomer made by Greene Tweed
- M** ..... International standard thread size designation (thread diameter in mm)
- mm** ..... Millimeter
- MG** ..... Identifies Grundfos motor type/size
- N** ..... Stainless
- NBR** ..... Buna - N (also known as Nitrile) – an elastic substance similar to rubber
- NEMA** ..... National Electrical Manufacturers Association
- PTFE** ..... Teflon®
- UNC** ..... Unified National Coarse – a standard for threads on bolts

Due to part changes over time, all position numbers (1-203) may not be used.

This column indicates which pump model uses the spare part. If blank, the part is used in all models.

\*\* 8 stage or less – 60 Hz, 12 stage or less – 50 Hz  
 \*\*\* 9 stage and up – 60 Hz, 13 stage and up – 50 Hz  
 (option\*\*\*) These components are used in the lower / hot section of Cool Top™ equipped pumps.

Spare Part Kits

Since certain pump parts can be expected to exhibit wear at the same time as related pump parts, they have been grouped into the following kits for your convenience. The numbers indicate the quantity of the part within each kit. Please order these kits using the kit material number at the top of the columns.

| BOTTOM BEARING KIT 1-14 |  |              |                           | Kit No. | 96416580 |
|-------------------------|--|--------------|---------------------------|---------|----------|
| Pos. No.                | Description                                | Material No. | Qty. Included in each Kit |         |          |
| 6g                      | Stationary Bottom Bearing Ring for Base    | 370130       | 1                         |         |          |
| 31                      | Allen Screw for Pos. 6g, M6 x 10mm         | 96406261     | 1                         |         |          |
| 32                      | Washer for Pos. 31, 12.5/ 6.4 x 1.6        | 00D3819      | 1                         |         |          |
| 47b                     | Bottom Bearing for Shaft, Tungston Carbide | 370069       | 1                         |         |          |
| 66                      | Washer for Shaft Bearing, Pos. 47b         | 370212       | 1                         |         |          |
| 66b                     | Lock Washer for Shaft Bearing              | 96417297     | 1                         |         |          |
| 67                      | Allen Screw for Shaft Bearing              | 96406259     | 1                         |         |          |
| D                       | Puller for Bottom Bearing 6g               | 00S0002      | 1                         |         |          |
| E                       | Allen Screw for Puller D, M8 x 50mm        | 00D6595      | 1                         |         |          |
| H                       | Distance Tool for Shaft Seal               | 985924       | 1                         |         |          |

| BEARING KIT 3-7  |                                  |              |                           | Kit No. | 96416574 |
|------------------|----------------------------------|--------------|---------------------------|---------|----------|
| BEARING KIT 8-14 |                                  |              |                           | Kit No. | 96416576 |
| Pos. No.         | Description                      | Material No. | Qty. Included in each Kit |         |          |
| 47a              | Intermediate Bearing with Driver | 290065       | 1                         | 2       |          |
| H                | Distance Tool for Shaft Seal     | 985924       | 1                         | 1       |          |

| WEAR PARTS KIT 1-2   |   |              |                           | Kit No. | 96416728 |    |
|----------------------|---|--------------|---------------------------|---------|----------|----|
| WEAR PARTS KIT 3-7   |   |              |                           | Kit No. | 96416729 |    |
| WEAR PARTS KIT 8-11  |   |              |                           | Kit No. | 96416730 |    |
| WEAR PARTS KIT 12-14 |   |              |                           | Kit No. | 96416731 |    |
| Pos. No.             | Description                               | Material No. | Qty. Included in each Kit |         |          |    |
| 45                   | Neck Ring                                 | 290091       | 2                         | 7       | 11       | 14 |
| 47                   | Chamber Bearing Ring, Bronze, 30mm        | 370023       | 1                         | 2       | 2        | 2  |
| 47                   | Chamber Bearing Ring, Graflon, 30mm       | 370214       | 1                         | 2       | 2        | 2  |
| 47c                  | Chamber Sleeve Bushing, Graflon, 22mm     | 370024       | 2                         | 6       | 9        | 12 |
| 47d                  | Lock Ring for Bearing Ring/Sleeve Bushing | 370213       | 2                         | 7       | 11       | 14 |
| 49c                  | Wear Ring for Impeller                    | 290049       | 2                         | 7       | 11       | 14 |
| 65                   | Neck Ring Retainer                        | 290059       | 2                         | 7       | 11       | 14 |
| H                    | Distance Tool for Shaft Seal              | 985924       | 1                         | 1       | 1        | 1  |

| GASKET KIT (EPDM) |   |                                  |                           | Kit No. | 96416597 |
|-------------------|---|----------------------------------|---------------------------|---------|----------|
| GASKET KIT (FKM)  |   |                                  |                           | Kit No. | 96416598 |
| Pos. No.          | Description                                 | Material No.                     | Qty. Included in each Kit |         |          |
| 37                | Sleeve O-ring, 197x4                        | 96408403<br>96408405             | 2                         |         | 2        |
| 38(a), 100        | Drain Plug O-ring, 16.3 x 2.4               | 00D1288<br>00D2231               | 6                         |         | 6        |
| 60                | Stack Compression Spring                    | 370175<br>370209                 | 4                         |         | 4        |
| 109               | Large O-ring for Seal Pos.105, 44.45x3.53   | 96407726                         | 1                         |         | 1        |
| 110               | O-ring for Seal Pos.105 to Shaft, 21.2x3.55 | 96411713<br>96407724<br>96411711 | 1                         |         | 1        |
| H                 | Distance Tool for Shaft Seal                | 985924                           | 1                         |         | 1        |

| SHAFT SEAL KIT, CARTRIDGE WITH O-RING |                                      |              |                           | Kit No. | 96416582 |   |   |   |   |   |
|---------------------------------------|--------------------------------------|--------------|---------------------------|---------|----------|---|---|---|---|---|
| 60 Hz = 1-8 stg. 50 Hz = 1-12 stg.    |                                      |              |                           | Kit No. | 96416583 |   |   |   |   |   |
|                                       |                                      |              |                           | Kit No. | 96416584 |   |   |   |   |   |
|                                       |                                      |              |                           | Kit No. | 96416586 |   |   |   |   |   |
|                                       |                                      |              |                           | Kit No. | 96416587 |   |   |   |   |   |
| SHAFT SEAL KIT, BALANCED CARTRIDGE    |                                      |              |                           | Kit No. | 96417021 |   |   |   |   |   |
| 60 Hz = 9-11 stg. 50 Hz = 11-14 stg.  |                                      |              |                           | Kit No. | 96417022 |   |   |   |   |   |
| (Maximum allowed working PSI is 580)  |                                      |              |                           | Kit No. | 96436727 |   |   |   |   |   |
|                                       |                                      |              |                           | Kit No. | 96436728 |   |   |   |   |   |
| Pos. No.                              | Description                          | Material No. | Qty. Included in each Kit |         |          |   |   |   |   |   |
| 105                                   | EUHE                                 | 985918       | 1                         |         |          |   |   |   |   |   |
|                                       | EUHV                                 | 985919       |                           | 1       |          |   |   |   |   |   |
|                                       | EUBE                                 | 985920       |                           |         | 1        |   |   |   |   |   |
|                                       | EUUE                                 | 985922       |                           |         |          | 1 |   |   |   |   |
|                                       | EUVV                                 | 985923       |                           |         |          |   | 1 |   |   |   |
|                                       | HUBE                                 | 985927       |                           |         |          |   |   | 1 |   |   |
|                                       | HUBV                                 | 985928       |                           |         |          |   |   |   | 1 |   |
|                                       | HUUE                                 | 985940       |                           |         |          |   |   |   |   | 1 |
|                                       | HUVV                                 | 985941       |                           |         |          |   |   |   |   | 1 |
| H                                     | Distance Tool for Shaft Seal         | 985924       | 1                         | 1       | 1        | 1 | 1 | 1 | 1 | 1 |
| N/A                                   | Grinding Device Tool for Emery Cloth | 370711       | 1                         | 1       | 1        | 1 | 1 | 1 | 1 | 1 |
| N/A                                   | Emery Cloth                          | 370712       | 1                         | 1       | 1        | 1 | 1 | 1 | 1 | 1 |

| SHAFT SEAL METAL BELLOWS   |                                      |              |                           | Kit No. | 96494662 |   |   |   |   |   |
|--|--------------------------------------|--------------|---------------------------|---------|----------|---|---|---|---|---|
| Working pressure up to 430 PSI   |                                      |              |                           | Kit No. | 96494663 |   |   |   |   |   |
| (for working pressure over 430 PSI, use Hxxx balanced seal as noted above) |                                      |              |                           | Kit No. | 96494664 |   |   |   |   |   |
|  |                                      |              |                           | Kit No. | 96494665 |   |   |   |   |   |
|  |                                      |              |                           | Kit No. | 96494666 |   |   |   |   |   |
|  |                                      |              |                           | Kit No. | 96494667 |   |   |   |   |   |
| Pos. No.   | Description                          | Material No. | Qty. Included in each Kit |         |          |   |   |   |   |   |
| 105  | KUHE                                 | 985942       | 1                         |         |          |   |   |   |   |   |
|  | KUHV                                 | 985943       |                           | 1       |          |   |   |   |   |   |
|  | KUBE                                 | 985944       |                           |         | 1        |   |   |   |   |   |
|  | KUBV                                 | 985945       |                           |         |          | 1 |   |   |   |   |
|  | KUUE                                 | 985946       |                           |         |          |   | 1 |   |   |   |
|  | KUVV                                 | 985947       |                           |         |          |   |   | 1 |   |   |
| H  | Distance Tool for Shaft Seal         | 985924       | 1                         | 1       | 1        | 1 | 1 | 1 | 1 | 1 |
| N/A  | Grinding Device Tool for Emery Cloth | 370711       | 1                         | 1       | 1        | 1 | 1 | 1 | 1 | 1 |
| N/A  | Emery Cloth                          | 370712       | 1                         | 1       | 1        | 1 | 1 | 1 | 1 | 1 |

Spare Part Kits (continued)

| IEC COUPLING KIT |                                      |              |                           | 24/22 | Kit No. | 96416589 |   |
|------------------|--------------------------------------|--------------|---------------------------|-------|---------|----------|---|
|                  |                                      |              |                           | 28/22 | Kit No. | 96416590 |   |
|                  |                                      |              |                           | 38/22 | Kit No. | 96416591 |   |
|                  |                                      |              |                           | 42/22 | Kit No. | 96416592 |   |
|                  |                                      |              |                           | 48/22 | Kit No. | 96416593 |   |
|                  |                                      |              |                           | 55/22 | Kit No. | 96416594 |   |
| Pos. No.         | Description                          | Material No. | Qty. Included in each Kit |       |         |          |   |
| 8                | Coupling CPL. w/Pos. 9, 1.5-2.2 kW   | 370703       | 1                         |       |         |          |   |
|                  | Coupling CPL. w/Pos. 9, 3.0-4.0 kW   | 370704       |                           | 1     |         |          |   |
|                  | Coupling CPL. w/Pos. 9, 5.5-7.5 kW   | 370710       |                           |       | 1       |          |   |
|                  | Coupling CPL. w/Pos. 9, 11.0-18.5 kW | 370035       |                           |       |         | 1        |   |
|                  | Coupling CPL. w/Pos. 9, 22 kW        | 370036       |                           |       |         |          | 1 |
|                  | Coupling CPL. w/Pos. 9, 30.0-37.0 kW | 370037       |                           |       |         |          | 1 |
| H                | Distance Tool for Shaft Seal         | 985924       | 1                         | 1     | 1       | 1        | 1 |

| NEMA COUPLING KIT |  |              |                           | 28.6/22 | Kit No. | 96417000 |   |
|-------------------|--|--------------|---------------------------|---------|---------|----------|---|
|                   |  |              |                           | 34.9/22 | Kit No. | 96417001 |   |
|                   |  |              |                           | 41.2/22 | Kit No. | 96417004 |   |
|                   |  |              |                           | 47.6/22 | Kit No. | 96417020 |   |
| Pos. No.          | Description                                    | Material No. | Qty. Included in each Kit |         |         |          |   |
| 8                 | Coupling CPL. w/Pos. 9, 182/184TC, 3-5 HP      | 370724       | 1                         |         |         |          |   |
|                   | Coupling CPL. w/Pos. 9, 213/215TC, 7 1/2-10 HP | 370725       |                           | 1       |         |          |   |
|                   | Coupling CPL. w/Pos. 9, 254-286TSC, 15-40 HP   | 370715       |                           |         | 1       |          |   |
|                   | Coupling CPL. w/Pos. 9, 324-365TS, 50-60 HP    | 370716       |                           |         |         | 1        |   |
| H                 | Distance Tool for Shaft Seal                   | 985924       | 1                         | 1       | 1       | 1        | 1 |

Accessories

| ANSI COMPANION FLANGES FOR LARGE CR                          |                                       |              |                           | Kit No. | 559601 |
|--|---------------------------------------|--------------|---------------------------|---------|--------|
| 2 1/2" Threaded Cast Iron, 125 Lb. Class, CR32-1-1 to CR32-5 |                                       |              |                           |         |        |
| Pos. No.   | Description                           | Material No. | Qty. Included in each Kit |         |        |
| N/A  | Nut, HEX 5/8"-11 UNC, Grade 2         | 00D1510      |                           |         | 8      |
| N/A  | Plain Bolt, 5/8" x 2-1/2", Grade 2    | 00D1920      |                           |         | 8      |
| N/A  | Flange, Cast Iron, 2 1/2"             | 00D1924      |                           |         | 2      |
| N/A  | Gasket Full Face Flange, 2 1/2", 150# | 550097       |                           |         | 2      |

| ANSI COMPANION FLANGES FOR LARGE CR                           |                             |              |                           | Kit No. | 345050 |
|---|-----------------------------|--------------|---------------------------|---------|--------|
| 2 1/2" Threaded Cast Iron, 250 Lb. Class, CR32-6 to CR32-11-2 |                             |              |                           |         |        |
| Pos. No.  | Description                 | Material No. | Qty. Included in each Kit |         |        |
| N/A   | Flange, Cast Iron, 2 1/2"   | 00D2744      |                           |         | 2      |
| N/A   | Hex Bolt, 3/4" x 3", 10 UNC | 00D0234      |                           |         | 16     |
| N/A   | Nut, 3/4"                   | 00D2746      |                           |         | 16     |
| N/A   | Gasket 2 1/2", 250#         | 00D2748      |                           |         | 2      |

| ANSI COMPANION FLANGES FOR LARGE CR                                |   |              |                           | Kit No. | 91121951 |
|--|---|--------------|---------------------------|---------|----------|
| 2 1/2" Threaded Stainless, 150 Lb. Class, CR(N)32-1-1 to CR(N)32-5 |   |              |                           |         |          |
| Pos. No.   | Description                               | Material No. | Qty. Included in each Kit |         |          |
| N/A  | Nut HEX 5/8"-11 UNC, 18-8 SS              | 00D00164     |                           |         | 8        |
| N/A  | HEX Screw, 5/8" x 2 3/4", 11 UNC, 18-8 SS | 00D7241      |                           |         | 8        |
| N/A  | Flange, Stainless Steel, 2 1/2"           | 91121942     |                           |         | 2        |
| N/A  | Gasket Full Face Flange, 2 1/2", 150#     | 550097       |                           |         | 2        |

| ANSI COMPANION FLANGES FOR LARGE CR                              |  |              |                           | Kit No. | 00D00138 |
|--|--|--------------|---------------------------|---------|----------|
| 2 1/2" Threaded 316 SS, 300 Lb. Class, CR(N)32-6 to CR(N)32-11-2 |  |              |                           |         |          |
| Pos. No.   | Description                                | Material No. | Qty. Included in each Kit |         |          |
| N/A  | Hex Screw, 3/4" x 3 1/4" - 10 UNC, 18-8 SS | 00D00144     |                           |         | 16       |
| N/A  | Nut, HEX 3/4" - 10 UNC, 18-8 SS            | 00D00154     |                           |         | 16       |
| N/A  | Flange, 316 Stainless Steel, 2 1/2" NPT    | 00D00255     |                           |         | 2        |
| N/A  | Gasket, 2 1/2", 250#                       | 00D2748      |                           |         | 2        |







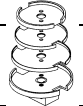

| NOTE: Base Adapter Kits are also available. |                                     |                           |   | Kit No. | 290843 | 290844 |
|---|-------------------------------------|---------------------------|---|---------|--------|--------|
| (Adapts the bases of CR(N)30 to CR(N)32)    |                                     |                           |   |         |        |        |
| Pos. No.                                    | Description                         | Qty. Included in each Kit |   |         |        |        |
| N/A   | CR30 to CR32 Base Adapter Kit 195mm | 1                         |   |         |        |        |
| N/A   | CR30 to CR32 Base Adapter Kit 220mm |                           | 1 |         |        |        |

| STACK KITS |                 |
|------------|-----------------|
| Model      | Material Number |
| CRN32-1-1  | 96416290        |
| CRN32-1    | 96416291        |
| CRN32-2-2  | 96416918        |
| CRN32-2-1  | 96416292        |
| CRN32-2    | 96416293        |
| CRN32-3-2  | 96416919        |
| CRN32-3    | 96416294        |
| CRN32-4-2  | 96416920        |
| CRN32-4    | 96416295        |
| CRN32-5-2  | 96416921        |
| CRN32-5    | 96416296        |
| CRN32-6-2  | 96416922        |
| CRN32-6    | 96416297        |
| CRN32-7-2  | 96416923        |
| CRN32-7    | 96416298        |
| CRN32-8-2  | 96416924        |
| CRN32-8    | 96416299        |
| CRN32-9-2  | 96416925        |
| CRN32-9    | 96416300        |
| CRN32-10-2 | 96416926        |
| CRN32-10   | 96416301        |
| CRN32-11-2 | 96416927        |
| CRN32-11   | 96416302        |
| CRN32-12-2 | 96416928        |
| CRN32-12   | 96416303        |
| CRN32-13-2 | 96416929        |
| CRN32-13   | 96416304        |
| CRN32-14-2 | 96416930        |
| CRN32-14   | 96416305        |

\*For 50 Hz operation only.  
NOTE: Stack Kits do not include seal, bottom bearing, or gasket kits, which must be ordered separately.



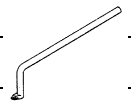

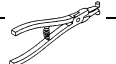
**SPECIAL TOOLS**

Tools not generally available from normal sources.



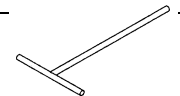

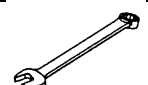
| MATERIAL NO.                                 | DESCRIPTION AND USE  |   |
|--|--|---|
| 00SV0003                                     | Holder with Pin for Dismantling and Assembly   |  |
| 00SV0015                                     | Punch for Pos. 6g, 47, 47c, 47d, 47e   |    |
| 00SV0043<br>00SV0044<br>00SV0045<br>00SV0046 | Holder for Wear Ring, Pos. 49c<br>CR(N) 32<br>CR(N) 45<br>CR(N) 64<br>CR(N) 90                         |  |
| 00SV0002                                     | Puller for Bottom Bearing, Pos. 6g   |    |
| 00ID6595                                     | Hexagon Socket Head Screw for Puller   |    |
| 00SV0025<br>00SV0027<br>00SV0028<br>00SV0029 | Punch for Fitting of Neck Ring/Retainer, Pos. 45a - 65<br>CR(N) 32<br>CR(N) 45<br>CR(N) 64<br>CR(N) 90 |   |
| 00SV0239                                     | Puller for Wear Ring, Pos. 49c   |  |
| 985924                                       | Forked Distance Piece for Shaft Seal   |    |
| 00SV0004                                     | Key for Split Cone Nut   |    |
| 00SV0047                                     | Pliers for Lock Ring   |  |

**STANDARD TOOLS**

In addition to being available from Grundfos, comparable tools can be purchased through normal sources.

| MATERIAL NO.                                 | DESCRIPTION AND USE   |   |
|--|---|---|
| 00SV0153<br>00SV0124<br>00SV0050<br>00SV0051 | Tee Key for Puller, Pos.:<br>105-(113)<br>31<br>26b-67<br>9-58a             |    |
| 00SV0055<br>00SV0054<br>00SV0096             | Key for Hexagon Socket Head Screws, Pos.:<br>28-58a<br>28a<br>28a           |  |
| 00SV0055<br>00SV0054<br>00SV0122<br>00SV0031 | Ring/Open-End Spanner for Pos.:<br>28a<br>28a-36a<br>28a-36-36a<br>21-23-25 |    |
| 00SV0031                                     | Hook Spanner (adjustable)   |  |

**TOOLS FOR TORQUES**

| MATERIAL NO.   | DESCRIPTION AND USE  |   |
|--|--|---|
| 00SV0292<br>00SV0269                                     | Torque Wrench  |    |
| 00SV0091<br>00SV0267<br>00SV0092<br>00SV0092             | Socket Spanner, Pos.:<br>28a<br>28a-36a<br>28a-36-36a<br>21-23-25                        |   |
| 00SV0296<br>00SV0297<br>00SV0298<br>00SV0094<br>00SV0093 | Socket Driver for Hexagon Socket Head Screws, Pos.:<br>31<br>26b-67-E<br>9-28-58a<br>28a |  |
| 00SV0295   | Ratchet Insert Tool for Socket Spanner, Pos.:<br>S                                       |    |
| 00SV0403   | Tap for Key for Split Cone Nut   |  |