

CRNE 3-HS

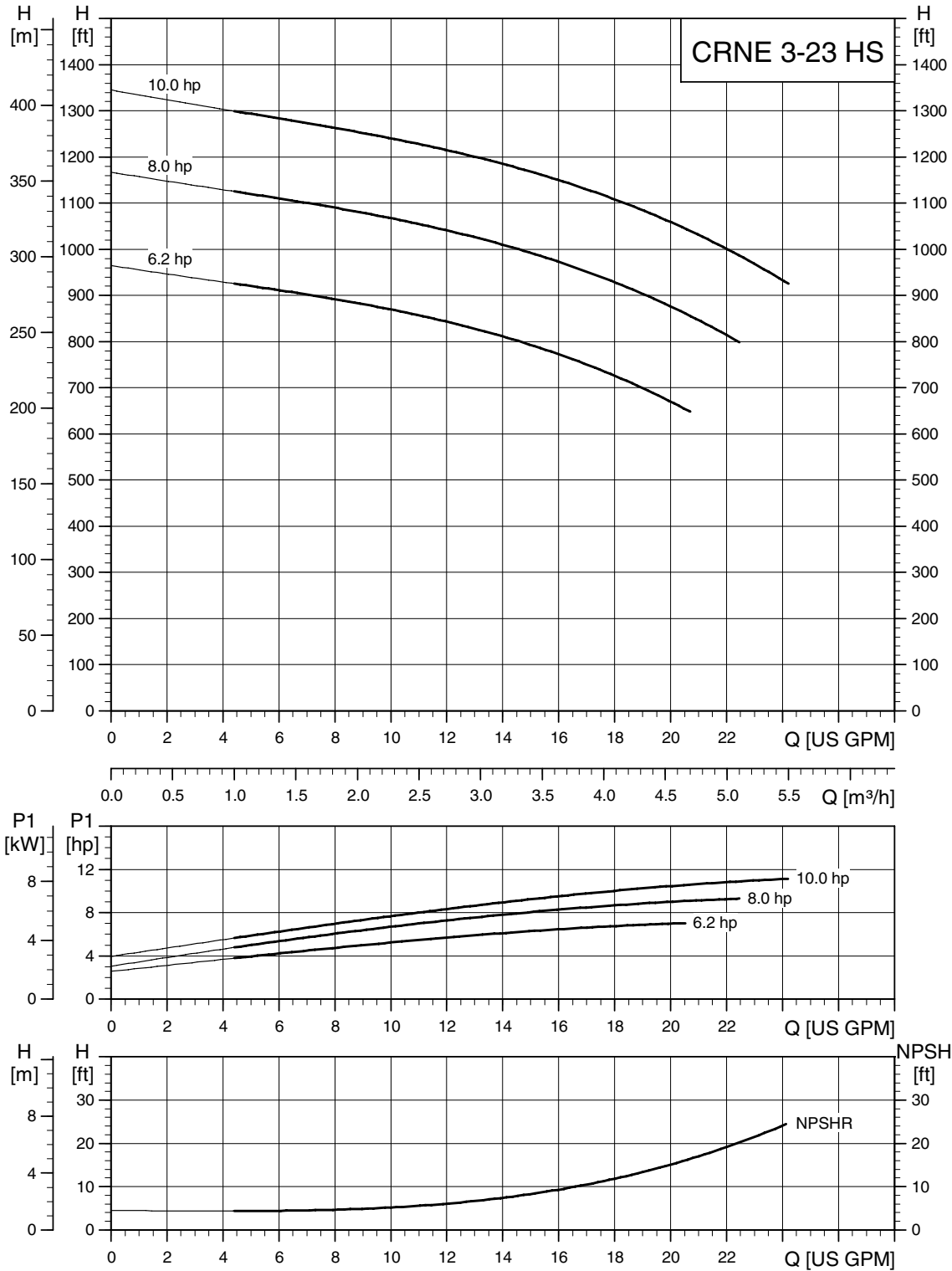

TM02 8309 2806

Dimensional sketch

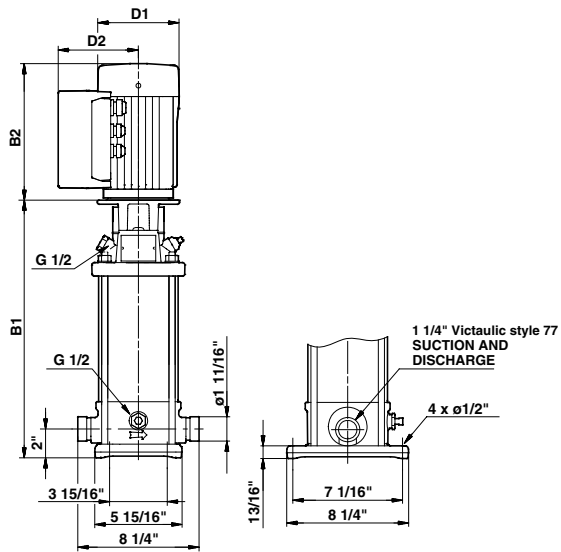

TM02 8847 1906

Dimensions and weights

Pump type	P2 [hp]	Dimensions [in]					Ship weight [lbs]
		PJE		B2	D1	D2	
		B1	B1 + B2				
CRNE 3-23 HS	6.2	26 7/8	14 3/4	41 1/2	8 3/4	7 1/2	148
CRNE 3-23 HS	8.0	26 7/8	15 1/2	42 1/4	8 3/4	7 1/2	157
CRNE 3-23 HS	10.0	26 7/8	15 1/2	42 1/4	8 3/4	7 1/2	168